

FOR INDIVIDUAL SLIDING DOORS

Maximum security.

3165LX.b ELECTRIC LOCKING SYSTEM

3165LX.b ELECTRIC LOCKING SYSTEM

The 3165LX.b system includes several versions of a system designed for locking, unlocking and propelling sliding doors in safety vestibules, in dayrooms or in high-traffic corridors.

Each 3165LX.b model utilizes an electric motor to operate the door through a rack and pinion drive mechanism. Doors are locked at top and bottom in both the open and closed positions by means of a concealed vertical lock bar at the rear jamb of the door. The vertical lock bar is deadlocked at a third locking point inside the horizontal cover box above the door. Standard clear door opening widths available are 3' 0" to 4' 6".

FUNCTION:

ELECTRIC - A remote switch activates a motor which raises a vertical lock bar and propels the door open or closed.

MECHANICAL - Manual unlocking is provided for each device. After being manually released, door movement is by hand. The door automatically deadlocks when moved to the fully open or closed position.



TECHNICAL DATA:

- COVER BOX:
1' 0-3/4" H x 7-1/2" D
- COVER BOX MATERIAL:
7 gauge steel plate
- HINGED PANEL:
10 gauge steel
- DOOR ROLLERS:
3" diameter, with sealed bearings
- VERTICAL LOCK BAR
DIMENSIONS:
5/8" SQ by full height of door
- FINISH: Prime paint
- DOOR HANGER:
7 gauge steel plate
- ELECTRICAL:
Motor: 1/8 HP, 115 VAC, 60 Hz., single phase power
Inrush: 1.1A
Running: .9A
Locked Rotor Current: 3.1A
- WIRE REQUIREMENTS:
When electric operation of the door is from a remote station, a minimum of five conductors (minimum 14 gauge) are required between the control point and the door, except for those models having the letter "K" (keyswitch) in the suffix. Keyswitch models require minimum six conductors.



FOR INDIVIDUAL SLIDING DOORS

Maximum security.

STANDARD FEATURES:

- Bottom door guide
- Door hanger
- Local mechanical release at cover box
- Sloped-front cover box
- Hinged cover panel for maintenance access
- Vertical lock bar assembly
- ASTM F1643 Certified
Horizontal and Vertical Impact Test-Grade 1
- Prime paint finish

OPTIONAL FEATURES:

PILASTER RELEASE - Hip-high paracentric keyed mechanical release mounted in a full-height pilaster adjacent to the receiving jamb.
Specify "3165LX.bP-1" keyed one side.
Specify "3165LX.bP-2" keyed two sides.

ELECTRIC KEYSWITCH -Paracentric or mogul keyed local electric control switch mounted below mechanical release mechanism in pilaster.

Specify "3165LX.bPK-1" for paracentric keyed one side.
Specify "3165LX.bPK-2" for paracentric keyed two sides.
Specify "3165LX.bPKM-1" for mogul keyed one side.
Specify "3165LX.bPKM-2" for mogul keyed two sides.

HOT DIP GALVANIZED FINISH - Available for external applications with lift-off cover panel only. Not available with standard hinged cover panel. Specify "G" when ordering. Example: 3165LX.b P-1G

REMOTE PANEL LOCK SYSTEM - Remote panel option is available with lift-off cover panel only. Not available with standard hinged cover panel. Specify "RP" when ordering. Example: 3165LX.bRP

DOOR SCHEDULE				
DOOR HEIGHT	CLEAR OPENING	FRAME OPENING	COVER BOX	DOOR WIDTH
8'-0" MAXIMUM	3'-0"	3'-7"	7'-4"	3'-2 1/2"
	3'-2"	3'-9"	7'-8"	3'-4 1/2"
	3'-4"	3'-11"	8'-0"	3'-6 1/2"
	3'-6"	4'-1"	8'-4"	3'-8 1/2"
	3'-8"	4'-3"	8'-8"	3'-10 1/2"
	4'-0"	4'-7"	9'-4"	4'-2 1/2"
	4'-4"	4'-11"	10'-0"	4'-6 1/2"
4'-6"	5'-1"	10'-4"	4'-8 1/2"	

NOTE: Cover box minimum length = (7" overtravel) + (2 x clear opening) + 9".

For doors exceeding 450 lbs. and/or greater than 4'-6" clear opening, contact factory. No cover box to exceed 6'0" clear opening

THREE HOUR FIRE DOOR RATING AVAILABLE. Standard cover box calculation does not apply to fire rated door.

3165LX.b ELECTRIC LOCKING SYSTEM

3165LX.bP-2 SLIDING DOOR SYSTEM

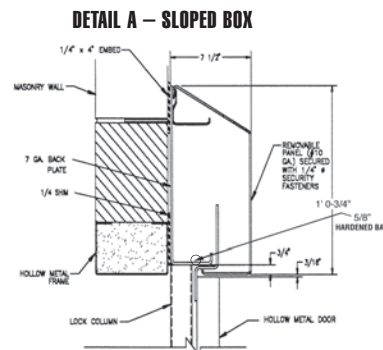
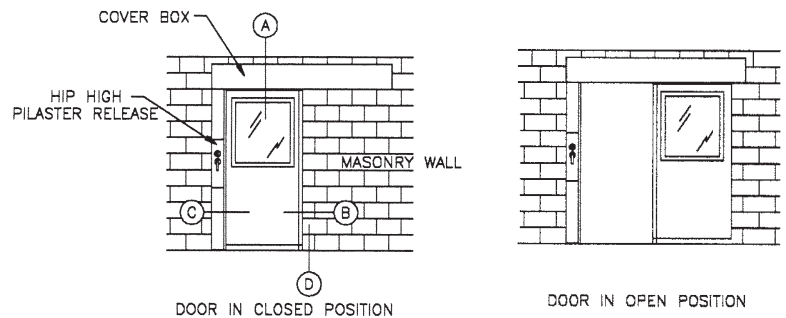

COVER BOX SECTION
7-1/2" deep x 1' - 0-3/4" tall
cover box field welded 1"
on 8" top and bottom.

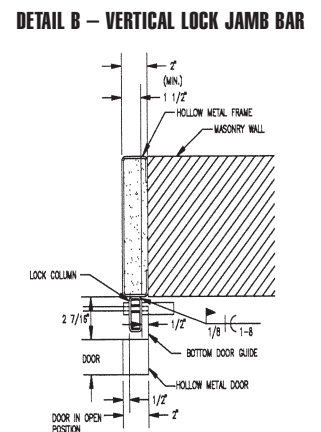

DETAIL C - PILASTER P2

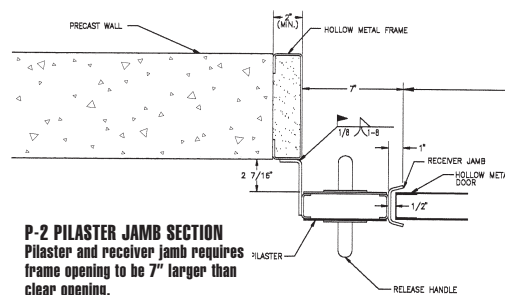

P-2 PILASTER JAMB SECTION
Pilaster and receiver jamb requires
frame opening to be 7" larger than
clear opening.

DETAIL D - BOTTOM DOOR GUIDE SECTION

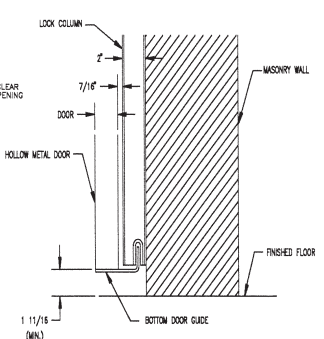

3165LX.bPKM-2 Shown

Note: Other system configurations and details are available.
Call Customer Service for more information.

