

JAMB MOUNTED FOR SWINGING DOORS

Minimum and medium security.

10300E-1: KEYED ONE SIDE
10300E-2: KEYED BOTH SIDES

APPLICATION:

Minimum and medium security swinging doors that are to be unlocked from a remote location. Jamb mounted. Door position indicator switch, door closer and heavy duty door pull are recommended.

FUNCTION:

ELECTRIC - Remote switch activates a solenoid which retracts the latchbolt. Latchbolt remains retracted until door is opened approximately 2", then it releases, automatically latches and deadlocks when the door is closed.

MECHANICAL - Latchbolt is retracted with a builder's hardware key at the door, and remains retracted until door is opened approximately 2", then it releases and automatically latches and deadlocks when the door is closed.

10300E SOLENOID OPERATED ELECTRO-MECHANICAL DEADLATCH



JAMB MOUNTED FOR SWINGING DOORS

Minimum and medium security.

STANDARD FEATURES:

- Deadlock indication switch
- Mechanical latchback
- Strike with security fasteners
- Faceplate with security fasteners
- Plug connector
- High power, dual coil solenoid with overload protection device
- Fail secure
- Mounting fasteners

Note #1: 1-11/16" O.D. x 1/8" wall cold drawn tubes furnished by hollow metal manufacturer.

OPTIONAL FEATURES:

NO LATCHBACK - Latchbolt remains retracted as long as control switch is activated. Latchbolt extends when power is removed. Specify "NL."

LOCAL ELECTRIC KEYSWITCH - Day key provides local electric operation and may be disabled from remote control point. Master key provides both electric and mechanical operation. Requires dual-function enhancement to builder's cylinder. Specify "LEK."

BUILDER'S HARDWARE CYLINDERS - Specify:

- "10300E-1" keyed one side.
- "10300E-2" keyed both sides.

KEY CYLINDER EXTENDER - Required whenever lock is keyed on stop side. Overall frame depth 4" minimum. Specify "KCE."

Full body rim cylinder required on stop side.
Full body mortise cylinder required on hinge side.

PROVIDE: (See Fig. 1)

1. Dimension "A"
(overall frame width)
2. Dimension "B"
(edge of frame to centerline of lockbolt)

10300E SOLENOID OPERATED ELECTRO-MECHANICAL DEADLATCH

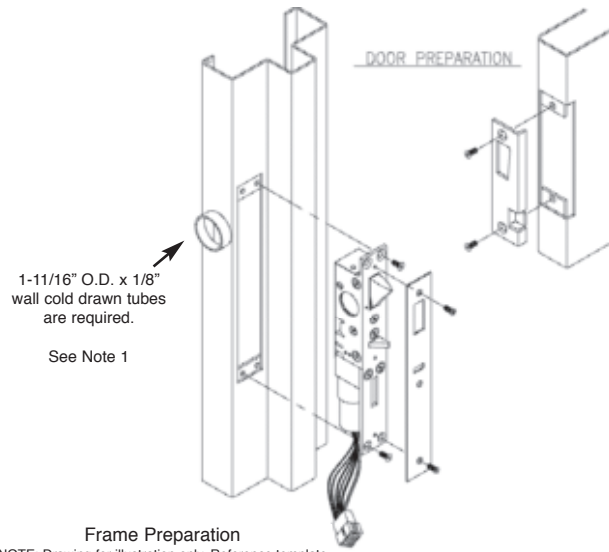

NOTE: Drawing for illustration only. Reference template for specific information.

Swing Chart: Specify circled swing number when ordering.

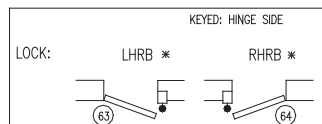
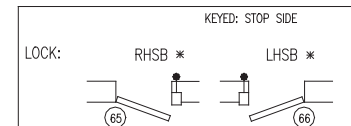
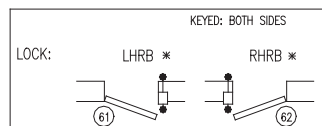

TECHNICAL DATA

- STANDARD FINISH: US32D
- LOCK BODY: Stainless steel
- FACE PLATE: Stainless steel
- LATCHBOLT: Stainless steel
- DEADLOCK ACTUATOR: Stainless steel
- ELECTRICAL: 24 VDC, 7.0 amp inrush, 0.6 amp seated
- LOCK SIZE: 10-5/8" H x 1-1/2" W x 1-3/4" D
- LOCK WEIGHT: 3.6 lbs.
- LATCHBOLT SIZE: 1-5/8" H x 5/8" TK
- LATCHBOLT THROW: 3/4"
- BUILDER'S CYLINDER: 1-5/32" diameter with standard Yale cam or equal
- UL Listed for use on three-hour fire doors.
- ASTM F1577 Certified Impact Test-Grade 1

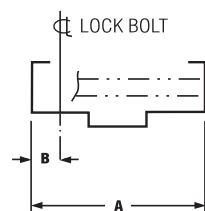

Fig. 1

